

EHD650

Wide Dynamic Range, True Day/Night
Vandal Color Dome Camera



Features

- 1/3" Pixim Digital Pixel System (DPS)
- 480 TVL of horizontal resolution
- Each pixel is processed independently, providing high quality images with enhanced dynamic range under extreme lighting conditions
- Superior Wide Dynamic image quality: Film-like colors are illustrated under various light conditions, even in high dynamic range scenes (> 120dB max.)
- True Day/Night with IR cut filter
- Vandal resistant: designed with polycarbonate shell to withstand the impact of a 10 lb sledgehammer
- Weatherproof IP66 rated to endure all weather conditions

Specifications

| | |
|-----------------------|--|
| Pickup Device | 1/3" Pixim Digital Pixel System |
| Pixel Element | 720 x 540 (Digital) |
| Horizontal Resolution | 480 TVL (Analog) |
| Sensitivity | 0.08 Lux / F=1.2 (DSS x 36) |
| Slow Shutter | Up to 32x (2, 4, 8, 16, 32) |
| S/N Ratio | Over 48dB |
| Auto Exposure | Yes |
| Auto White Balance | Yes, 2500K ~9500K (Adjustable) |
| Backlight Comp. | Yes |
| Auto Iris | Yes |
| Video Output | BNC, 1.0Vp-p / 75 ohm |
| Auto Gain Control | Yes (max. 38dB) |
| Wide Dynamic Range | 95dB typical, 120dB max. |
| Sync. Mode | Line Lock/Internal Sync. |
| Image Flip | Yes (Horizontal Reverse) |
| On Screen Display | Yes |
| Lens | f=2.9~10mm |
| Power Source | 24VAC |
| Operating Temperature | -40°C ~ 50°C / -40°F ~ 122°F (20% ~ 80% Humidity) |
| Power Consumption | 6W max. (w/out heater) 20.5W max. (w/heater) |
| Dimension (W x H x D) | 130 x 98.9 x 130 mm / 5.1" x 3.9" x 5.1" |

Dimensions

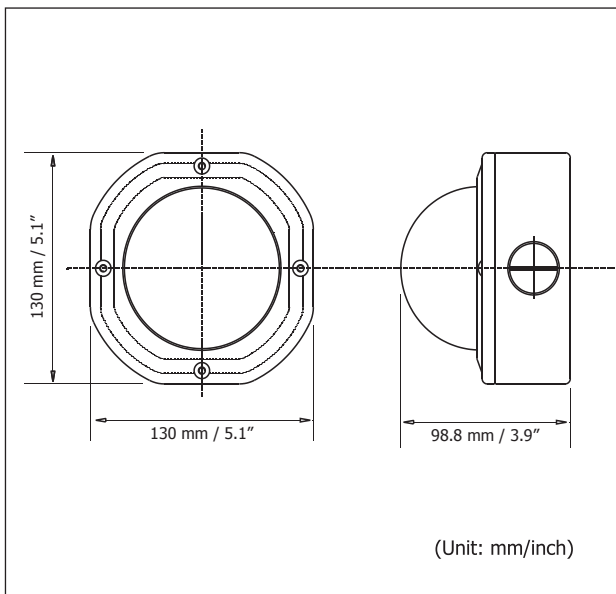

Ordering Information

- **EHD650/H-3:** 1/3" Wide Dynamic, True Day/Night Rugged Vandal Dome Color Camera, 2.9~10mm Lens